

K1112

Fitting Kit

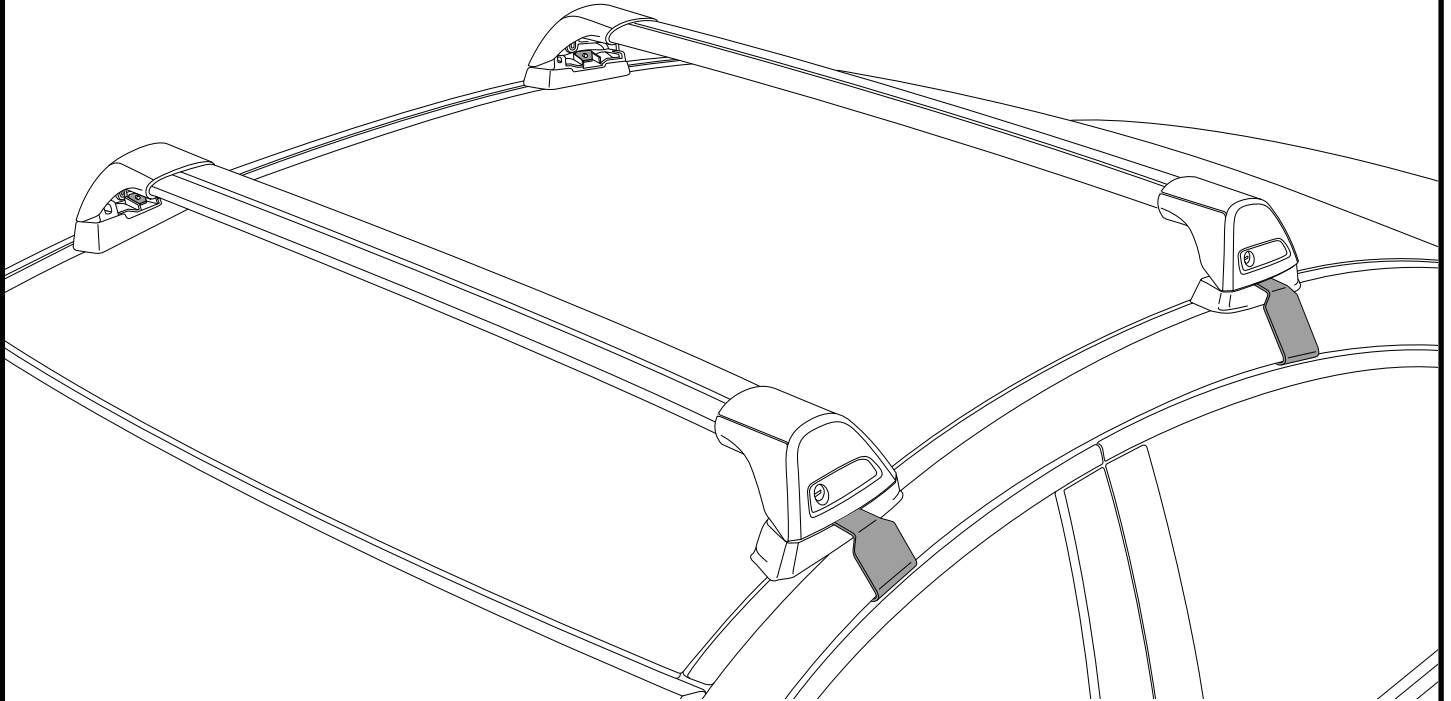

**REQUIRED • ERFORDERLICH • REQUERIDOS • OBLIGATOIRE • NØDVENDIG • NECESSÁRIO • ОБЯЗАТЕЛЬНО • OBBLIGATORIO
 POTRZEBY • NEVYHNUTELNÉ • NEVYHNUTNÉ • NODIG • NÖDVÄNDIG • PÅKRÆVET • ПОТРІБНА • EDellyTETÄÄN**

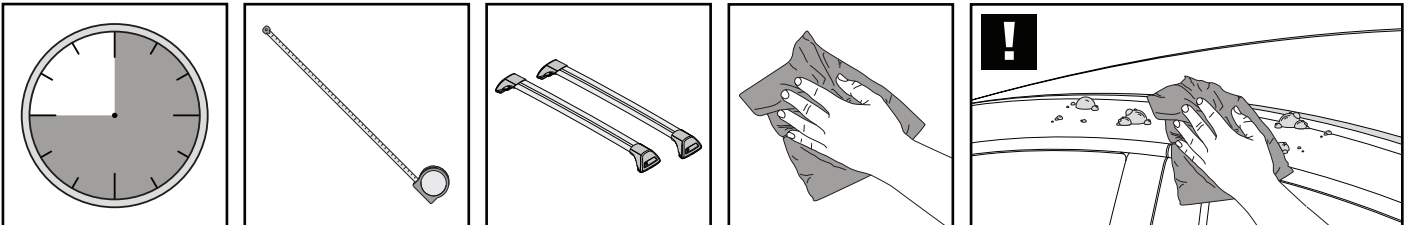

**MAXIMUM kg (lb) • MAXIMUM kg • MÁXIMO kg • MAXIMUM kg • MAKSIMALT kg • MÁXIMO kg
 МАКСИМУМ кг • MASSIMO kg • MAKSIMALNEJ kg • MAXIMÁLNÍ kg • MAXIMÁLNE kg
 MAXIMUM kg • MAXIMAL kg • MAKSIMAL kg • МАКСИМАЛЬНА kg • ENIMMÄISMÄÄRÄ kg**

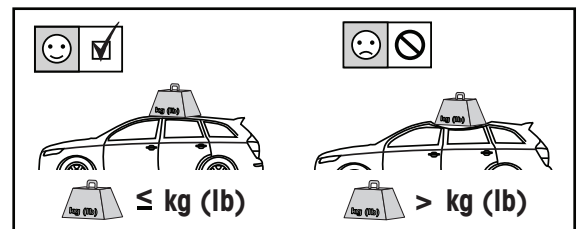
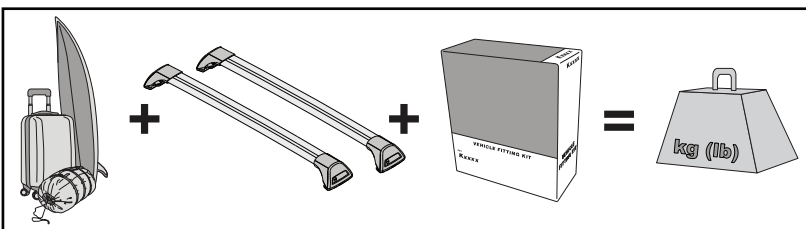

Toyota Ist, 5dr Hatch 02-07	NZ	60 kg (132 lb)	60 kg (132 lb)

**CONTENTS • INHALT • CONTENIDO • CONTENU • INNHOLD • CONTEÚDO • СОДЕРЖАНИЕ • CONTENUTO
ZAWARTOŚĆ • OBSAH • OBSAH • INHOUD • INNEHÅLL • INDHOLD • ЗМІСТ • SISÄLLYS**

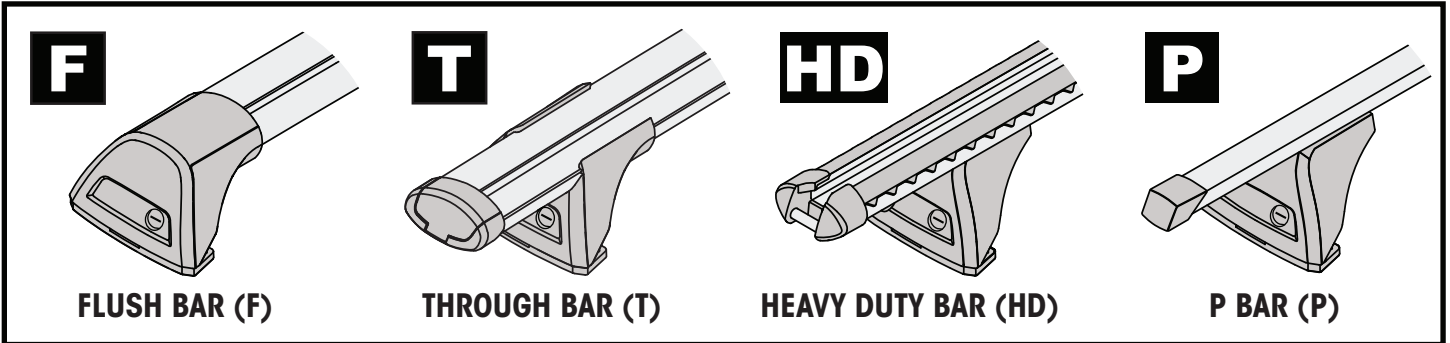
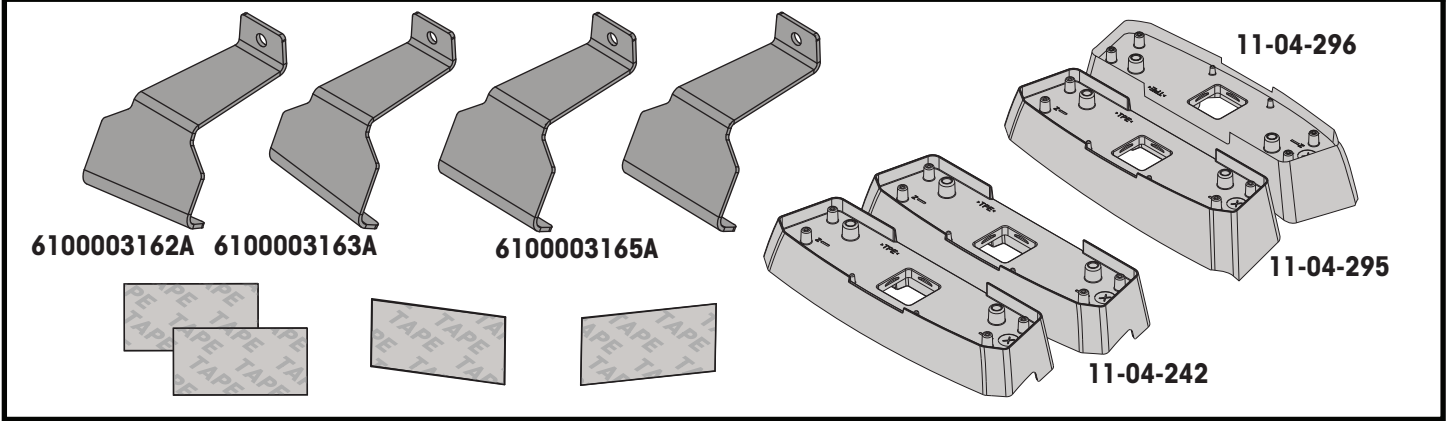

**ATTENTION • ACHTUNG • ATENCIÓN • ATTENTION • OPPMERKSOMHET • ATENÇÃO • ВНИМАНИЕ • ATTENZIONE
UWAGA • UPOZORNĚNÍ • UPOZORNENIE • LET OP • UPPMÄRKSAMHET • OPMÆRKSOMHED • УВАГА • HUOMIO**

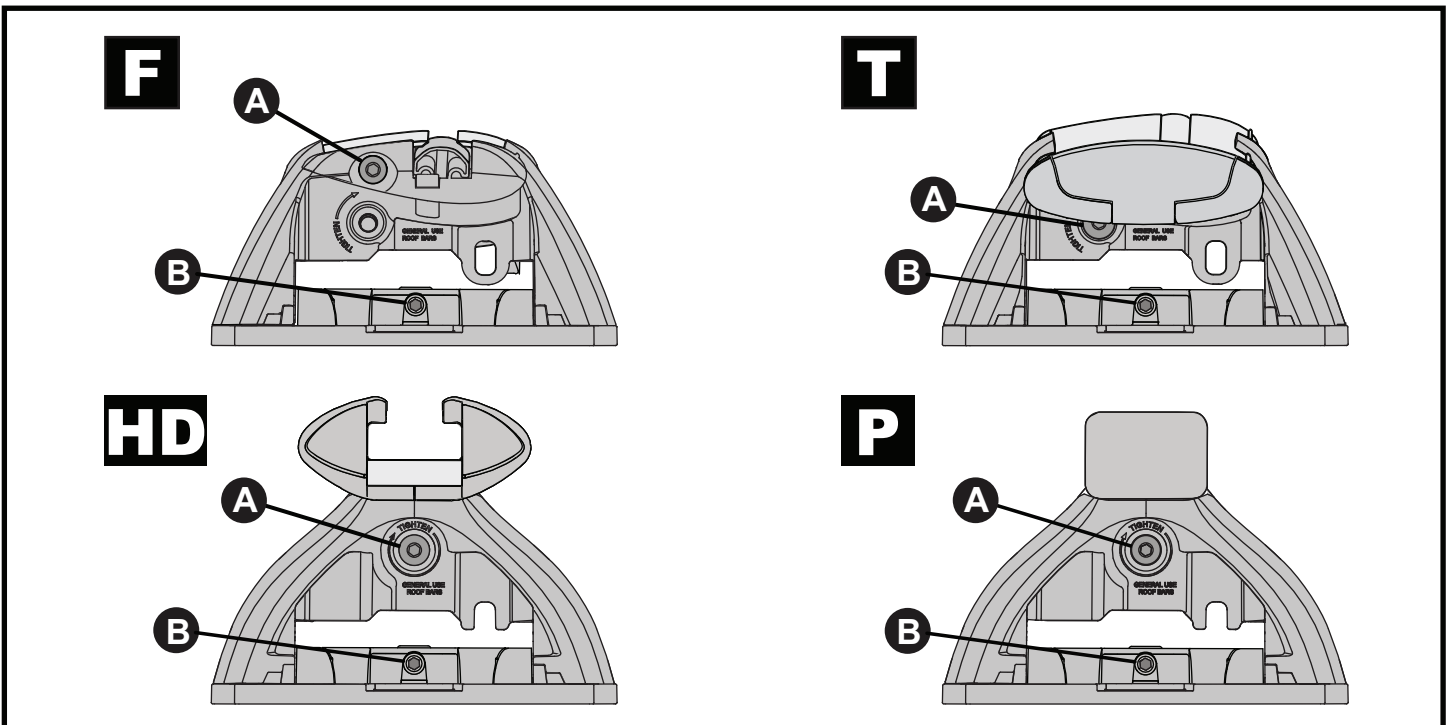
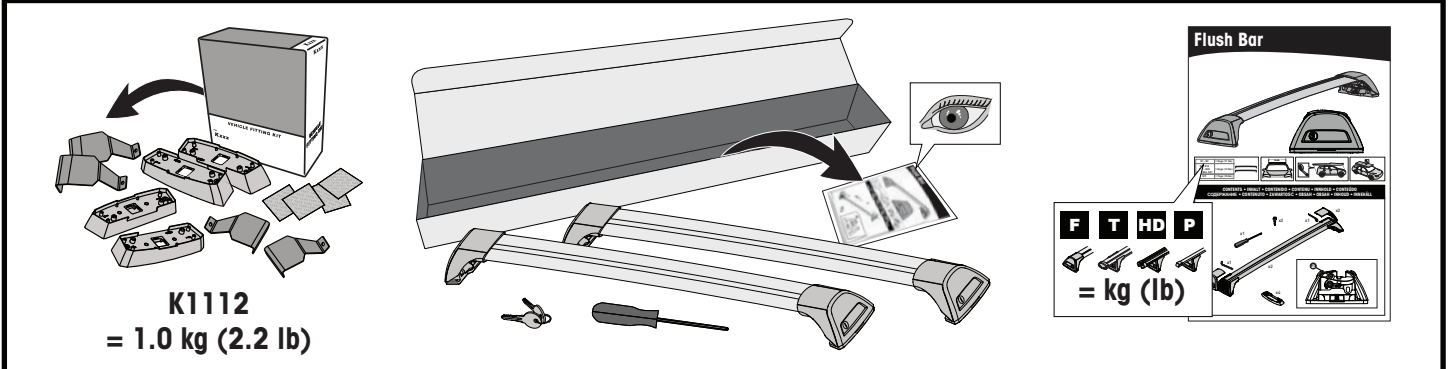

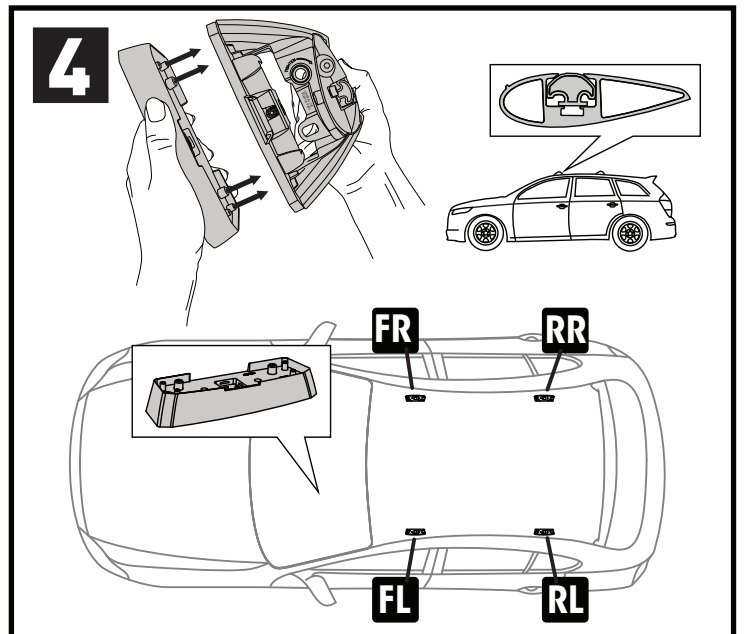
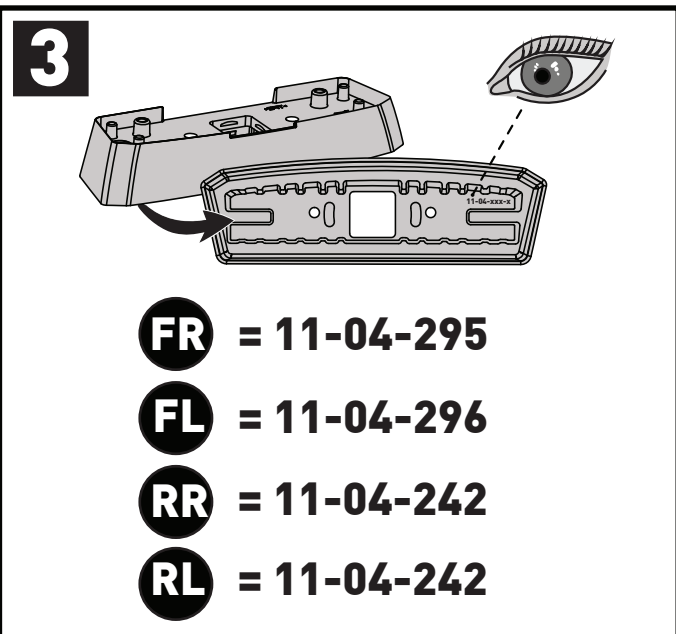
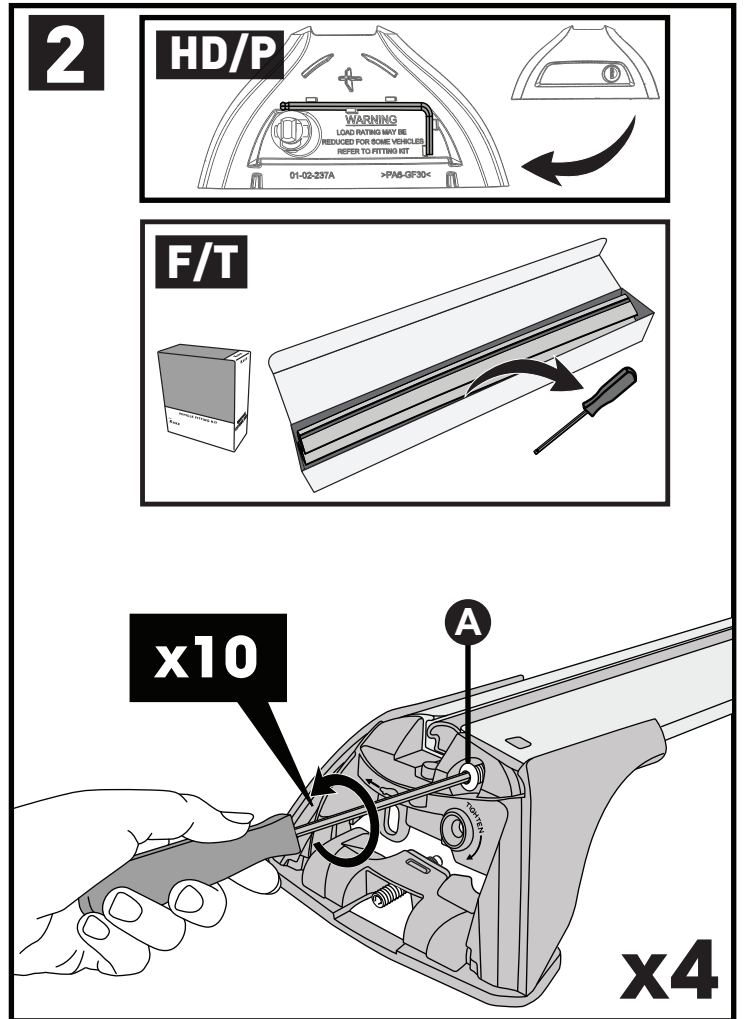
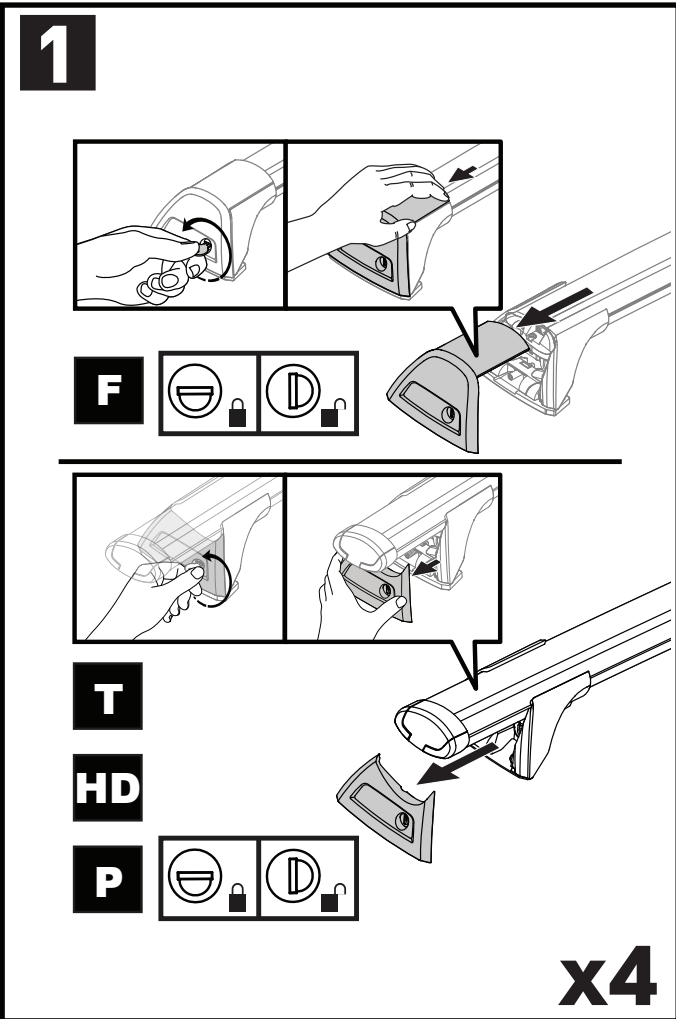
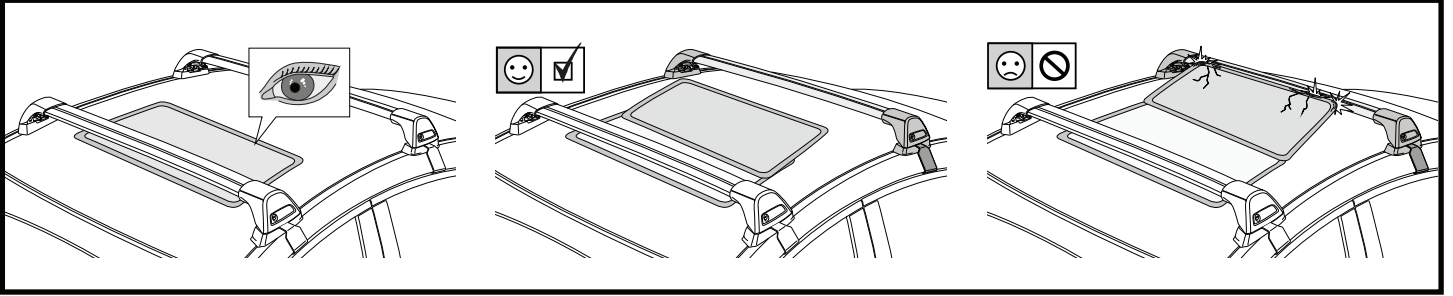

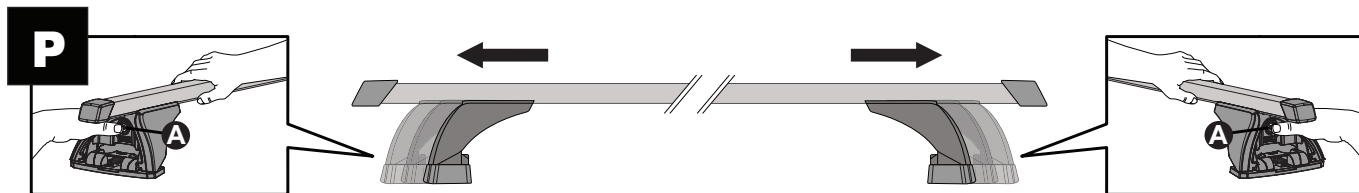
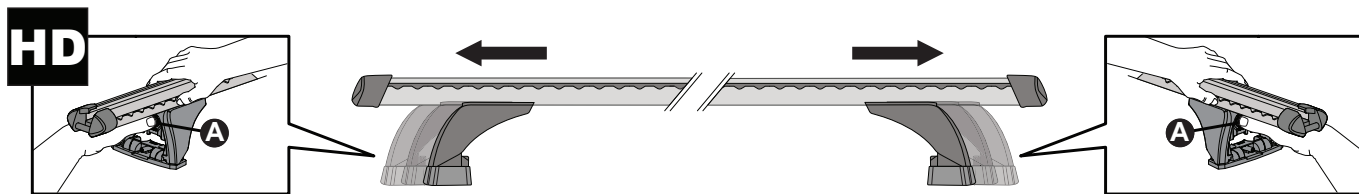
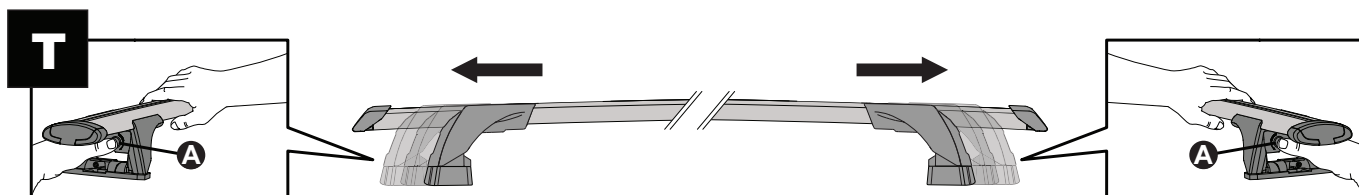
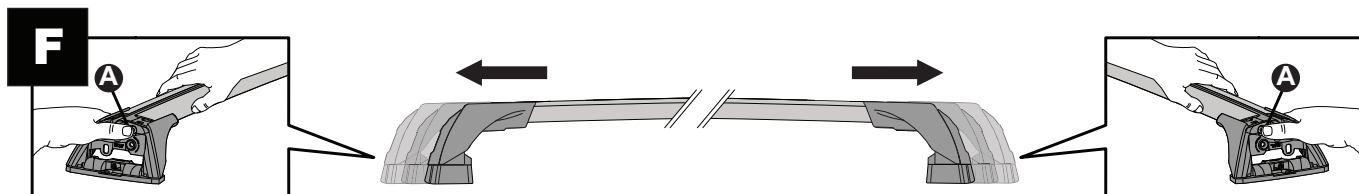
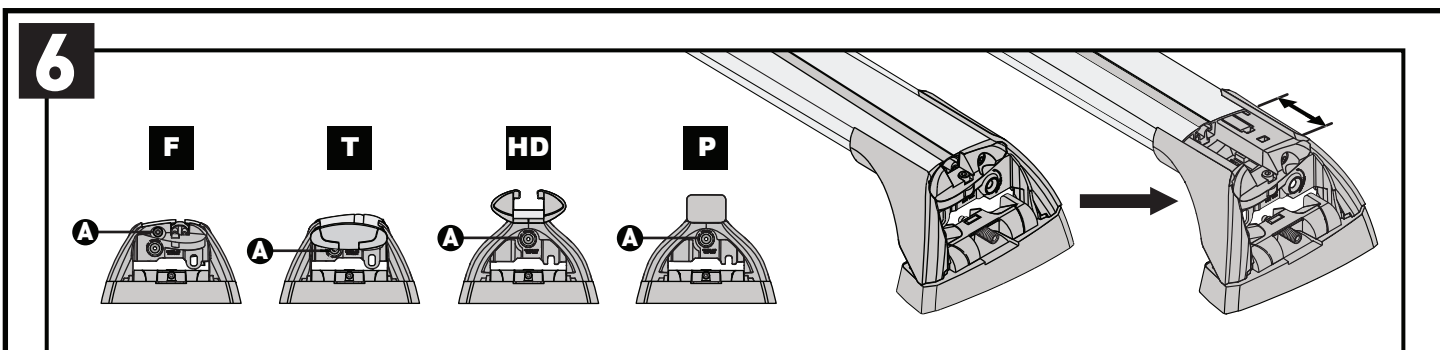
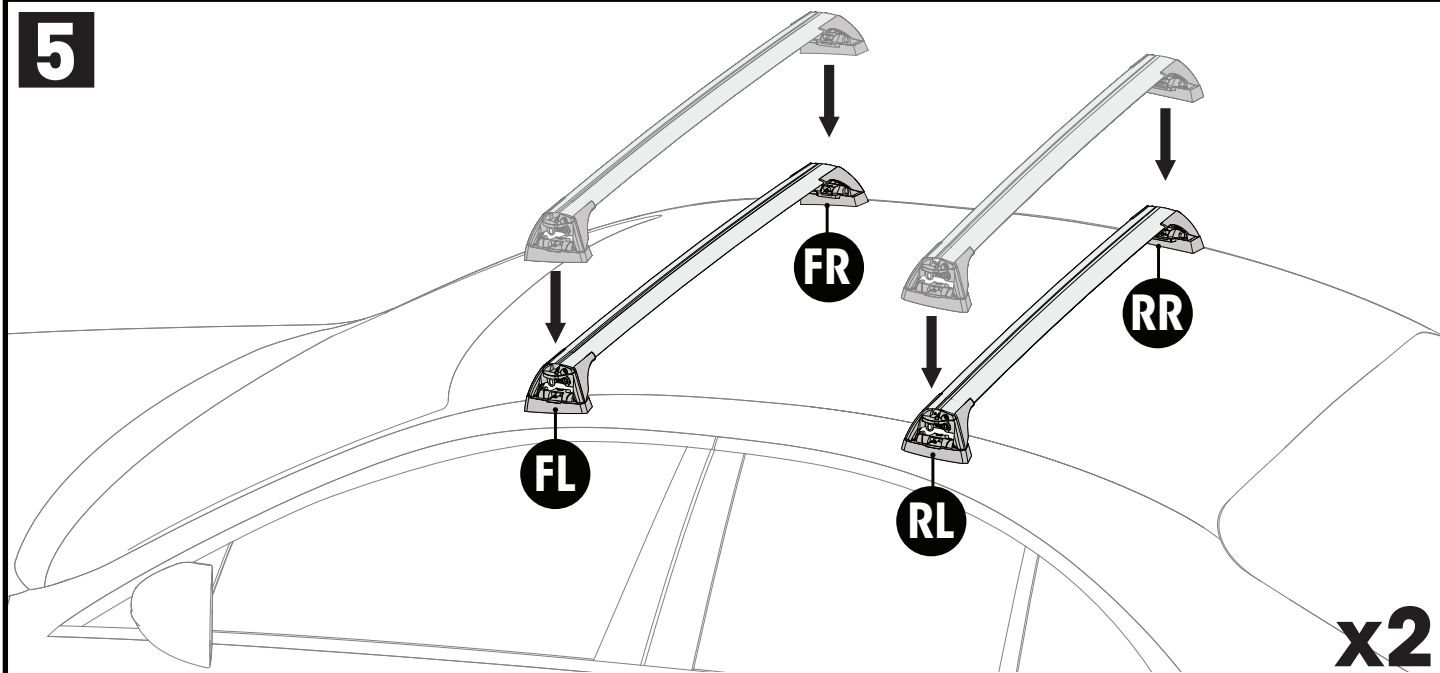

7

mm / inches

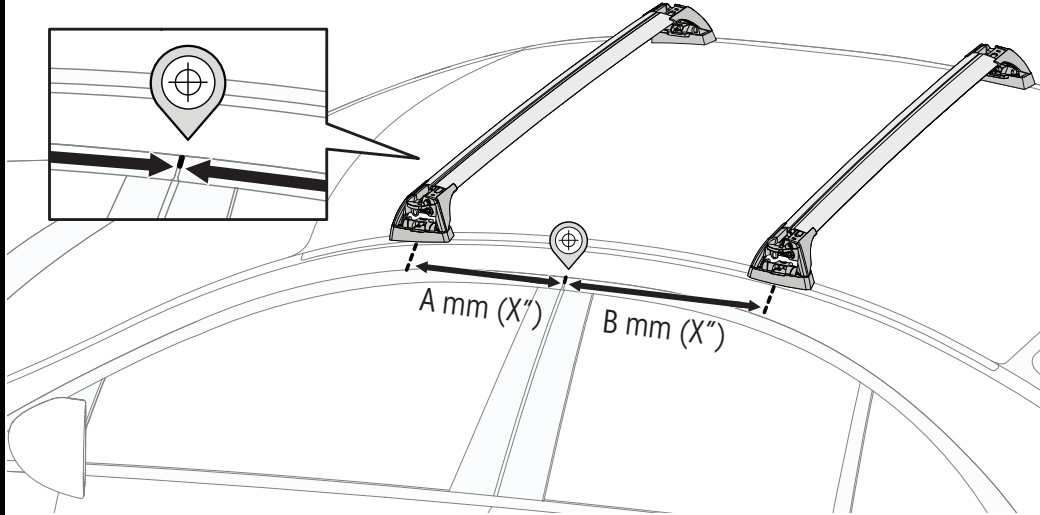
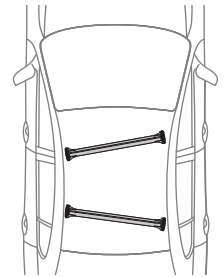
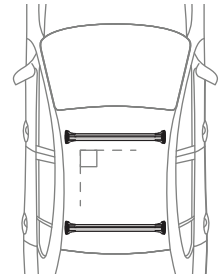

A

B

Toyota Ist, 5dr Hatch 02-07

NZ

A = 275 mm (10 7/8")

B = 430 mm (16 7/8")

PLACEMENT • PLATZIERUNG • COLOCACIÓN • MONTAGE • PLASSERING • COLOCAÇÃO • РАЗМЕЩЕНИЕ • MONTAGGIO
 UMIESZCZENIE • UMÍSTĚNÍ • UMIESTNENIE • PLAATSING • PLACERING • PLACERING • РОЗМІЩЕННЯ • SIJOITTA

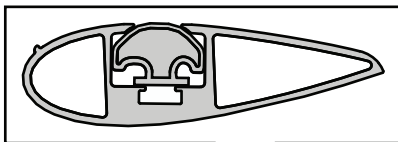
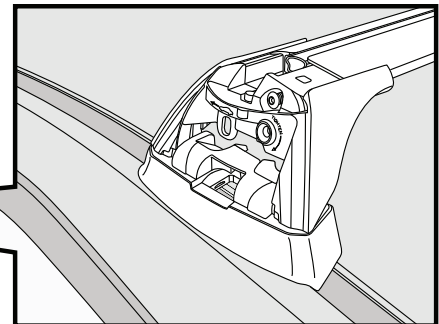
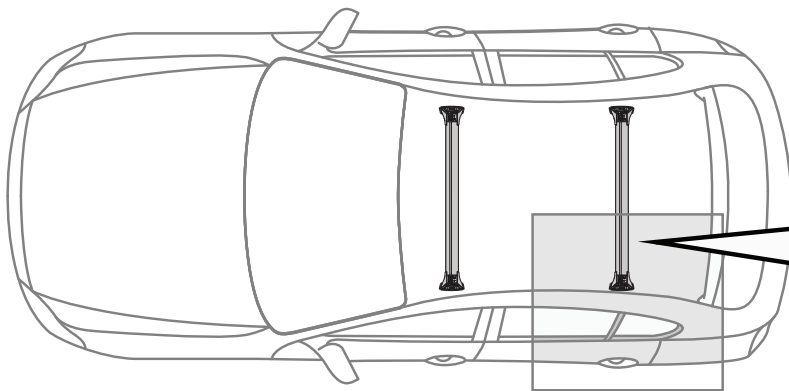
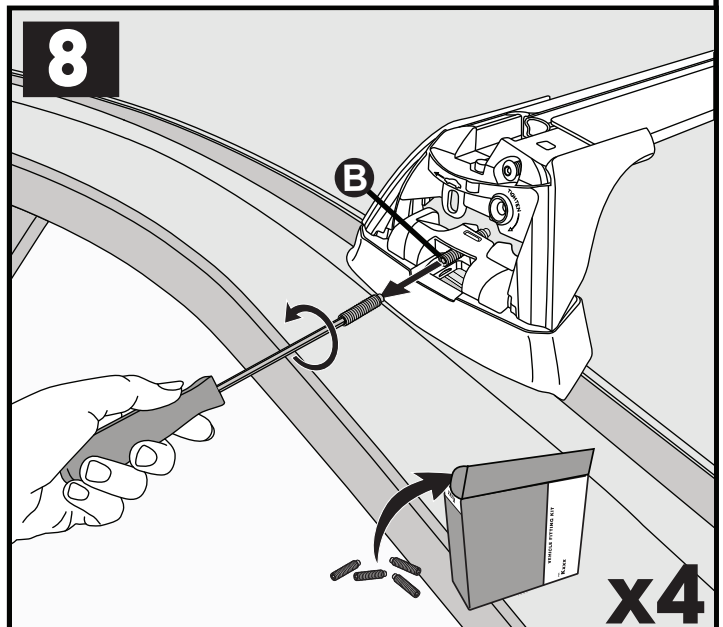
**8**

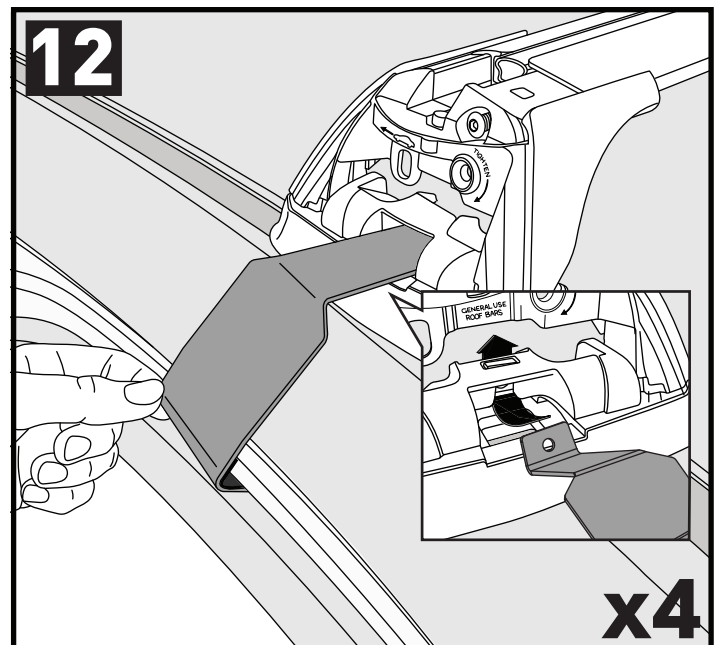
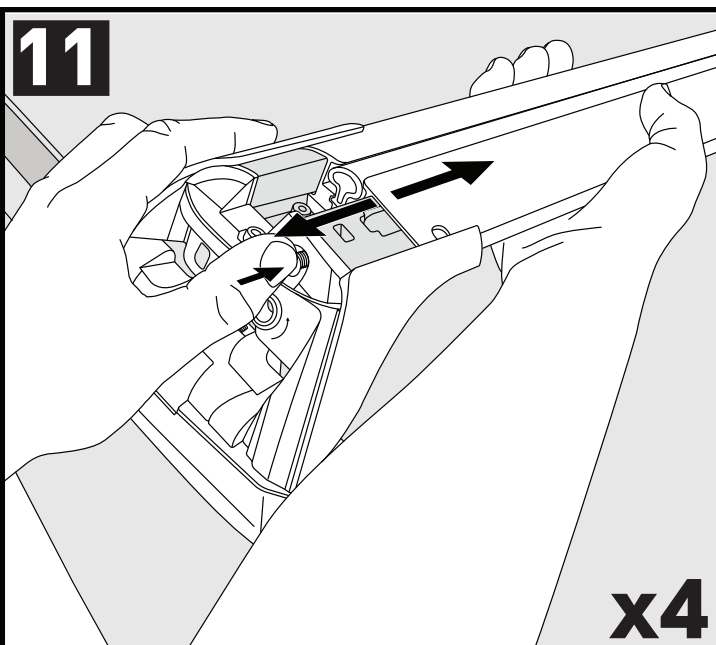
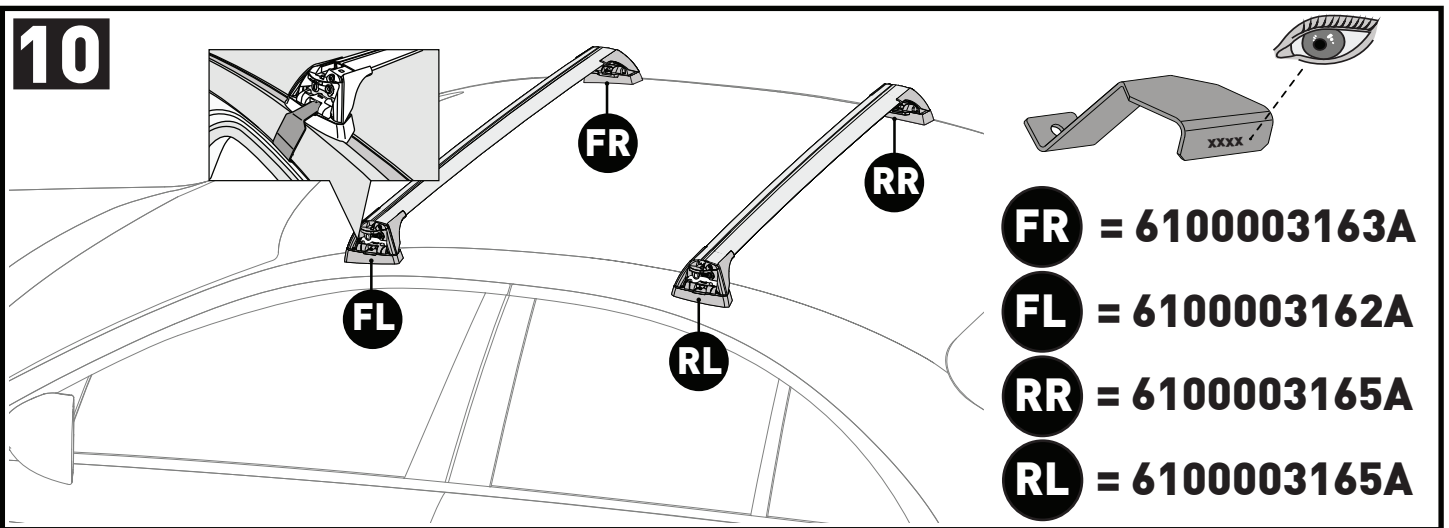
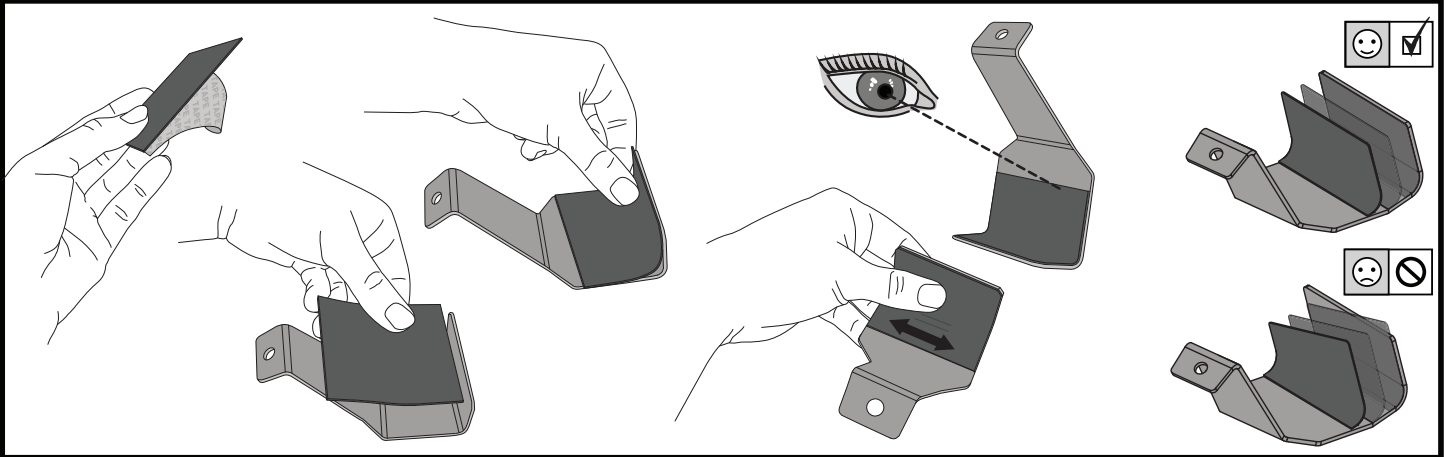
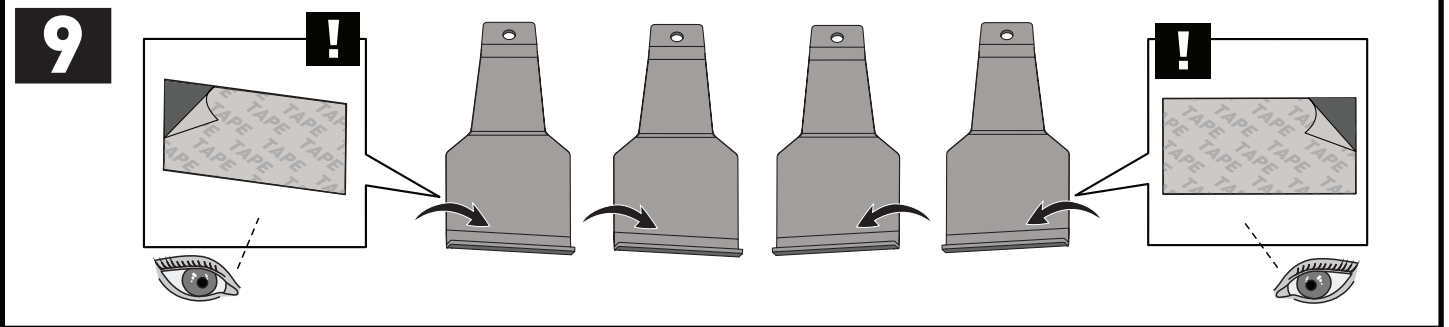

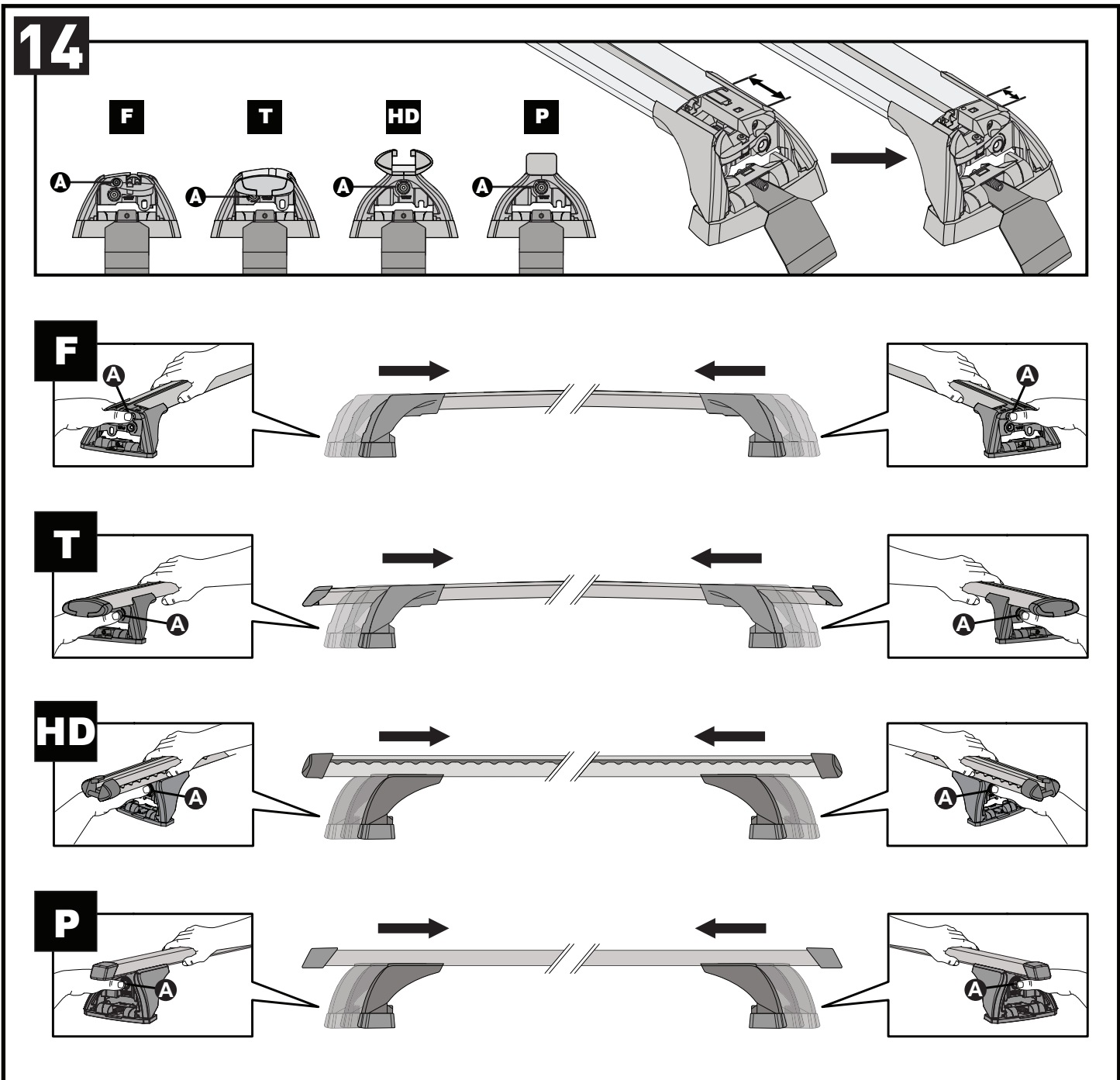
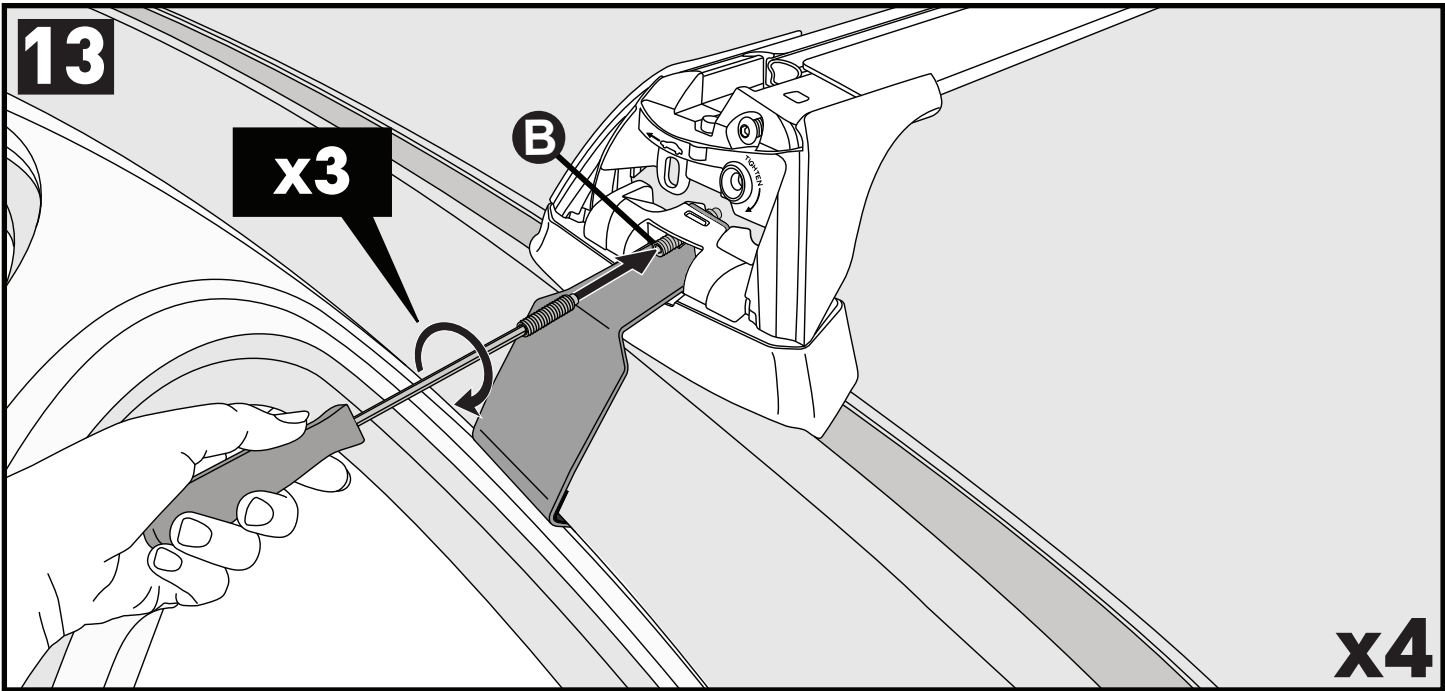

CLOSE • GESCHLOSSEN • CERRAR • FERMER • LUKKE • FECHAR • ЗАКРЫТЬ • CHIUDERE • BLISKO ZAVŘÍT • ZAVRIĚT • GESLOTEN • STÄNGA • LUK • ЗАКРИТИ • SULKEA

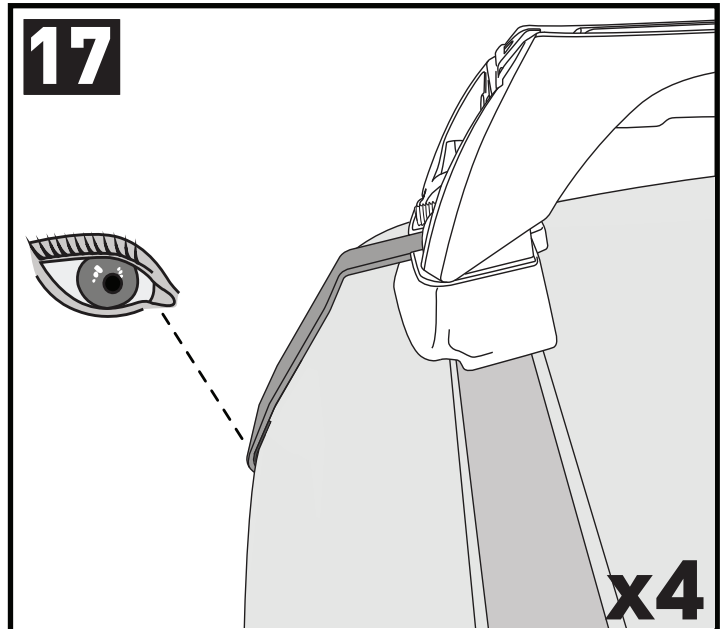
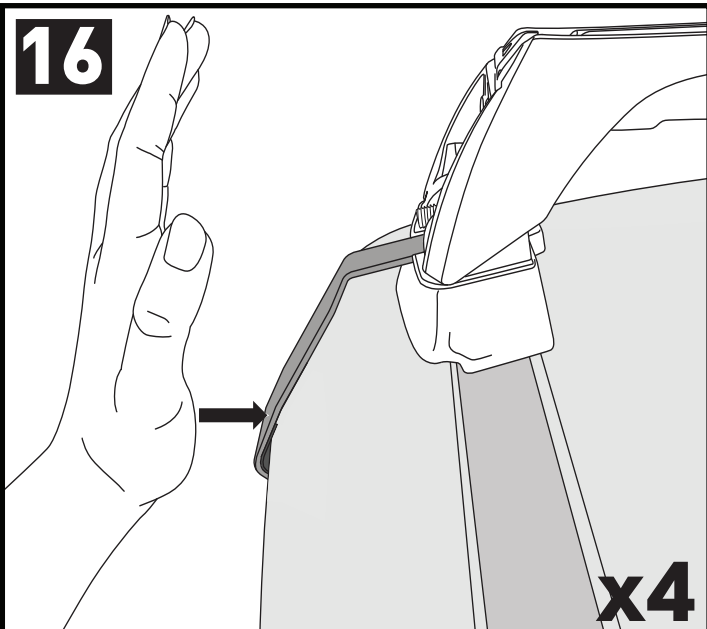
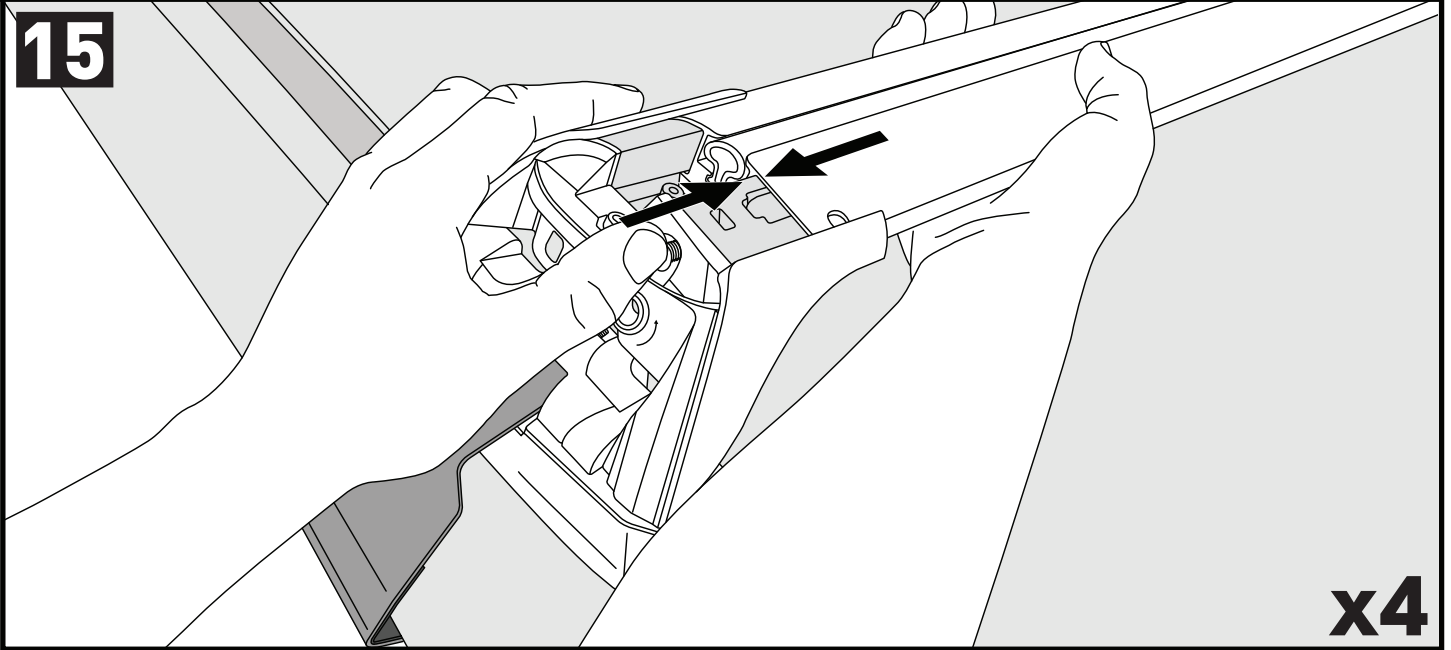

ATTENTION • ACHTUNG • ATENCIÓN • ATTENTION • OPPMERKSOMHET • ATENÇÃO • ВНИМАНИЕ • ATTENZIONE UWAGA • UPOZORNĚNÍ • UPOZORNENIE • LET OP • UPPMÄRKSAMHET • OPMÆRKSOMHED • УВАГА • HUOMIO

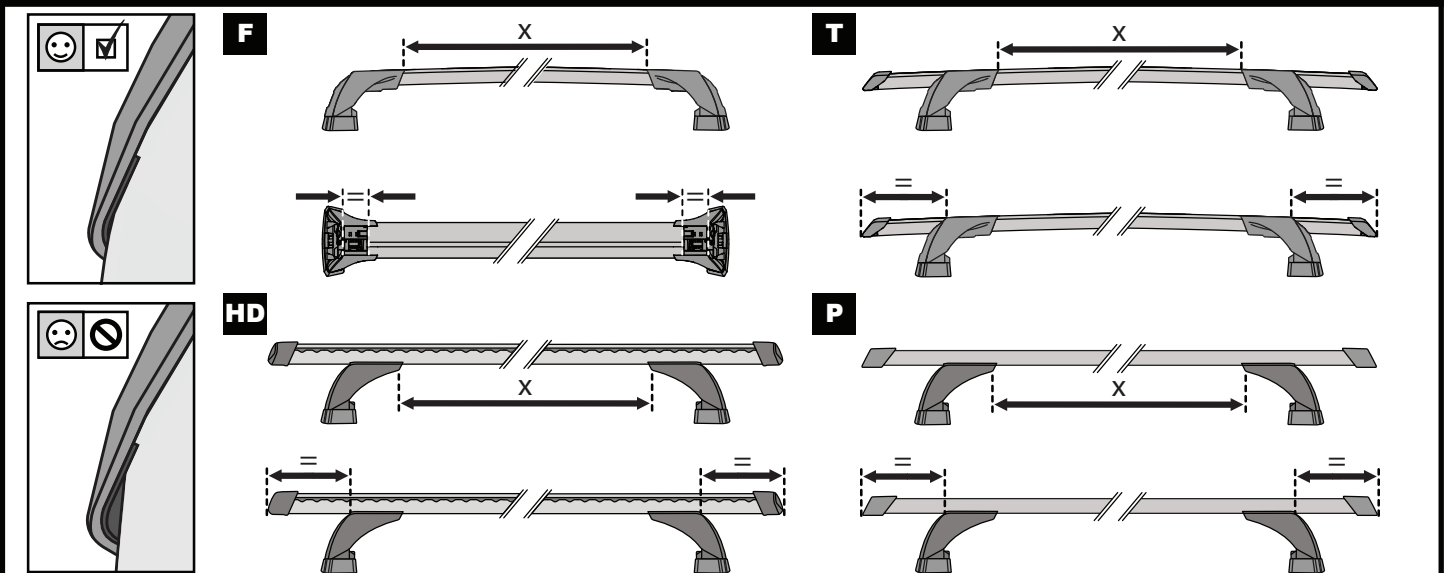

18

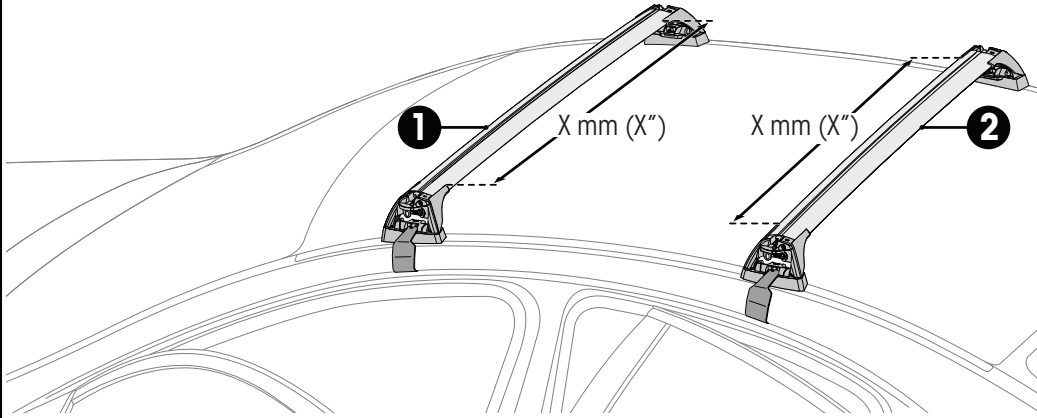

F

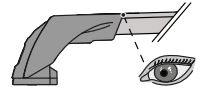

T

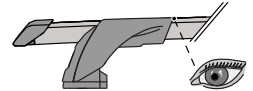

HD

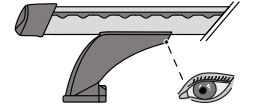

P

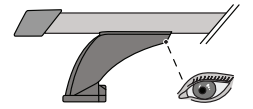

		1	2
Toyota Ist 5dr Hatch 02-07	NZ	X = 805 mm (31 3/4")	X = 780 mm (30 3/4")

19

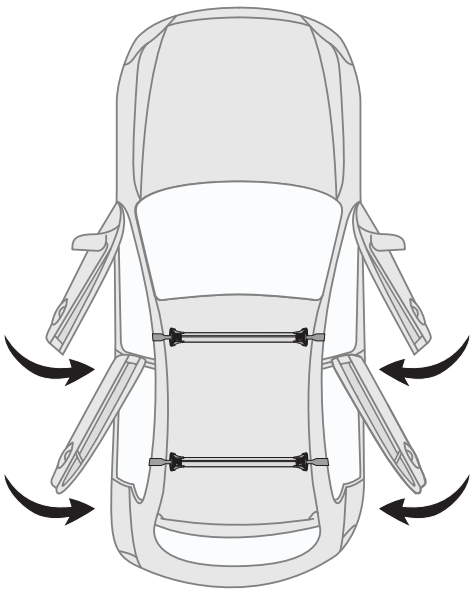

20



7 mm / inches

Make Model, Variant, xdr, xdr Vehicle Type xx+	A	B
AU, NZ, CN, US, EU, ZA	xxxx mm (xxx inches)	xxxx mm (xxx inches)
AU, NZ, CN, US, EU, ZA	xxxx mm (xxx inches)	xxxx mm (xxx inches)
AU, NZ, CN, US, EU, ZA	xxxx mm (xxx inches)	xxxx mm (xxx inches)

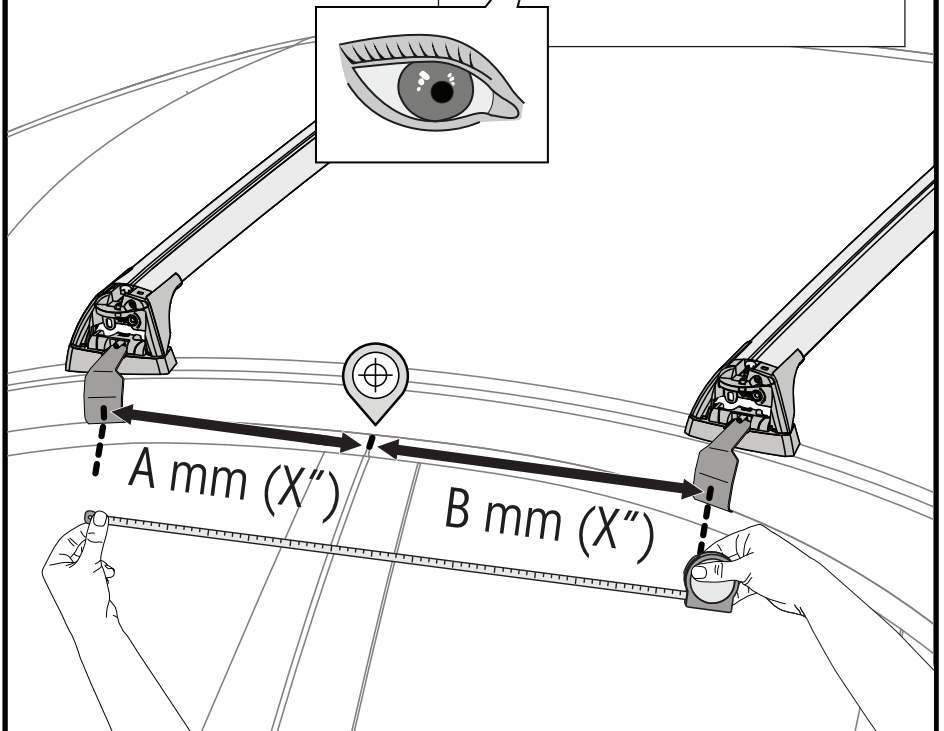

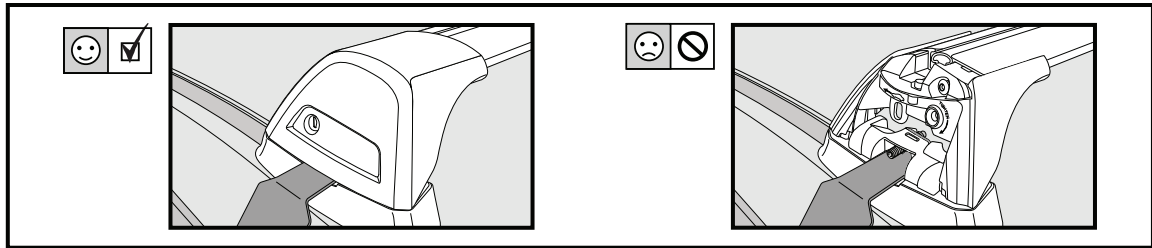
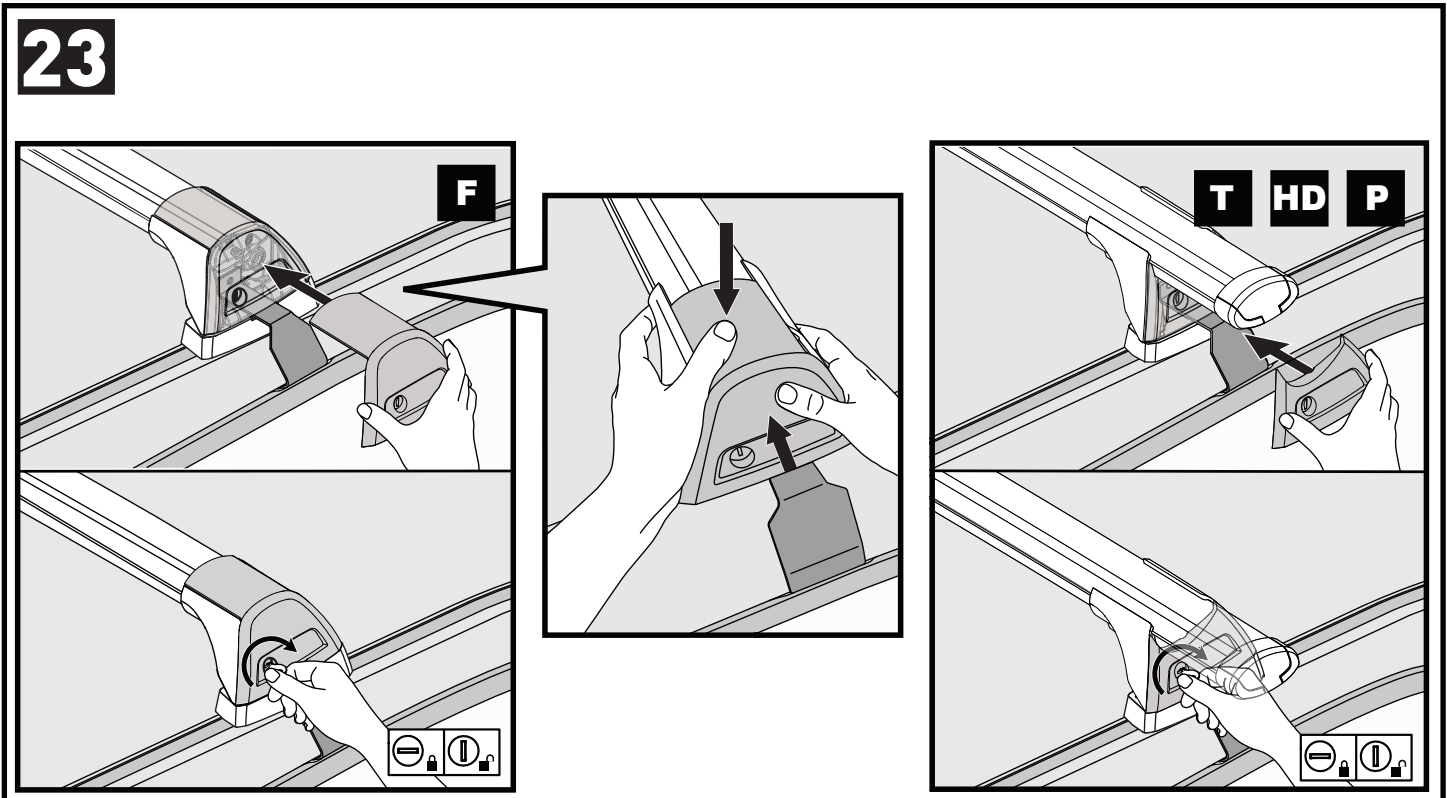
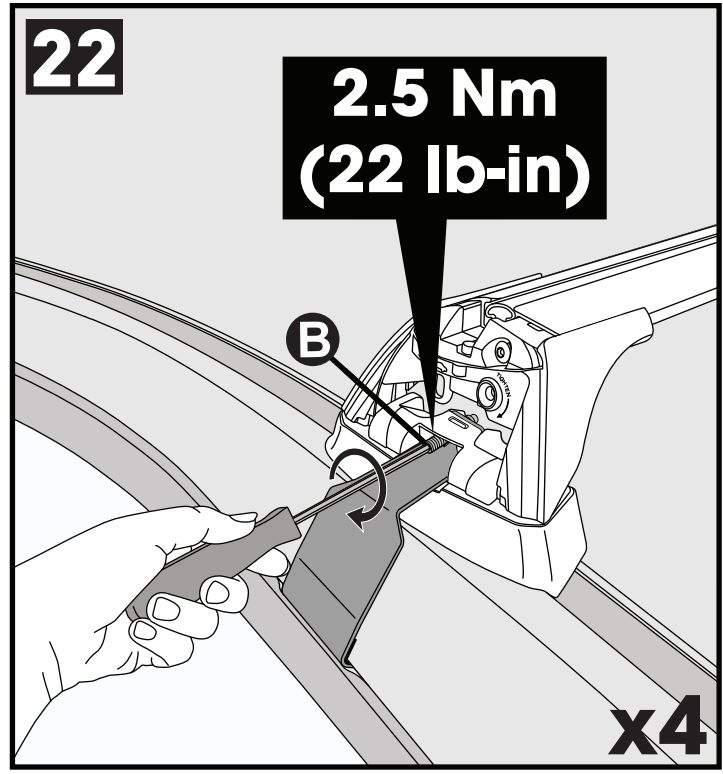
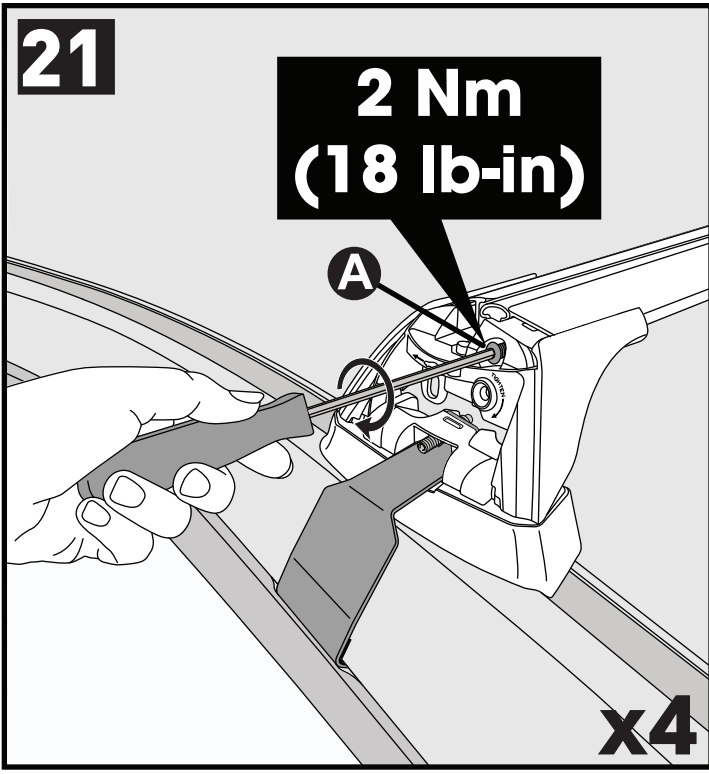

x4

24

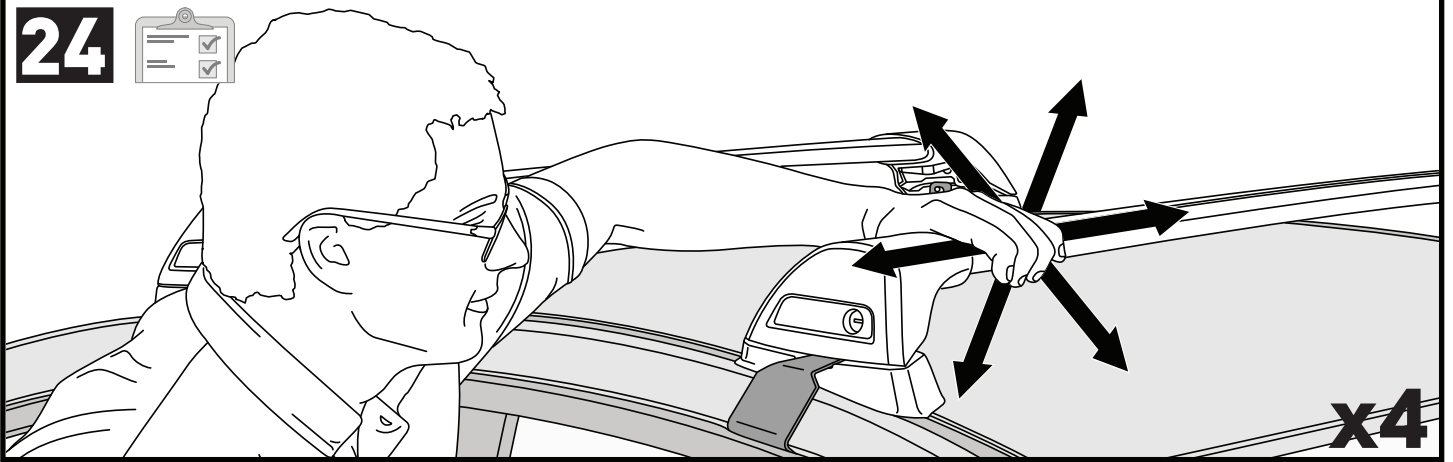

**ATTENTION • ACHTUNG • ATENCIÓN • ATTENTION • OPPMERKSOMHET • ATENÇÃO • ВНИМАНИЕ • ATTENZIONE
UWAGA • UPOZORNĚNÍ • UPOZORNENIE • LET OP • UPPMÄRKSAMHET • OPMÆRKSOMHED • УВАГА • HUOMIO**

- EN** Please read safety and warranty booklet included with this product prior to use. For more information visit your local dealer.
- DE** Bitte lesen und beachten Sie die beiliegende Montageanleitung, Sicherheitshinweise und Garantiebedingungen bevor Sie das Produkt montieren/benutzen. Für weitere Informationen kontaktieren Sie bitte Ihren Händler.
- ES** Por favor, lea folleto de seguridad y garantía que se incluye con este producto antes de su uso. Para obtener más información, visite a su distribuidor local.
- FR** Veuillez lire attentivement le manuel de sécurité et de garantie avant utilisation. Pour plus d'informations, visitez votre concessionnaire local.
- NO** Vennligst les hefte om sikkerhet og garanti som er vedlagt dette produkt før det tas i bruk. For mer informasjon ta kontakt med din forhandler.
- PT** Por favor leia o manual de segurança e garantia incluído, antes de utilizar o produto. Para mais informações visite o seu revendedor local.
- RU** Пожалуйста, ознакомьтесь с инструкцией перед тем, как использовать товар. Для получения более подробной информации обратитесь к местному дилеру.
- IT** Si prega di leggere il libretto di sicurezza e garanzia incluso nel prodotto prima dell'uso. Per maggiori informazioni visita il rivenditore locale.
- PL** Proszę zapoznać się z warunkami gwarancji i bezpieczeństwa przed użyciem produktu. W celu uzyskania dodatkowych informacji proszę kontaktować się z najbliższym autoryzowanym punktem sprzedaży.
- CS** Před použitím si prosím přečtete příložené informace o bezpečnosti a záručních podmínkách. Pro více informací navštivte nejbližšího dealera.
- SK** Pred použitím si prosím prečítajte priložené informácie o bezpečnosti a záručných podmienkach. Pre viac informácií navštívte najbližšieho diera.
- NL** A.U.B. bijgesloten garantie- en veiligheidsinstructies grondig lezen voor gebruik van dit product. Voor meer informatie graag contact opnemen met uw dealer.
- SV** Var snäll och läs igenom säkerhets- och garantihäftet som medföljer produkten före användning. För mer information besök din lokala återförsäljare.
- DK** Læs venligst sikkerheds- og garantibogholderen, der følger med dette produkt, inden brug. For mere information besøg din lokale forhandler.
- UA** Будь ласка, ознайомтеся з броюрою безпеки та гарантії, включені до цього продукту перед використанням. Для отримання додаткової інформації відвідайте місцевого дилера.
- FI** Lue tämän tuotteen mukana toimitetut turvallisuus- ja takuu huoltopalvelut ennen käyttöä. Lisätietoja saat paikalliselta jälleenmyyjältä.

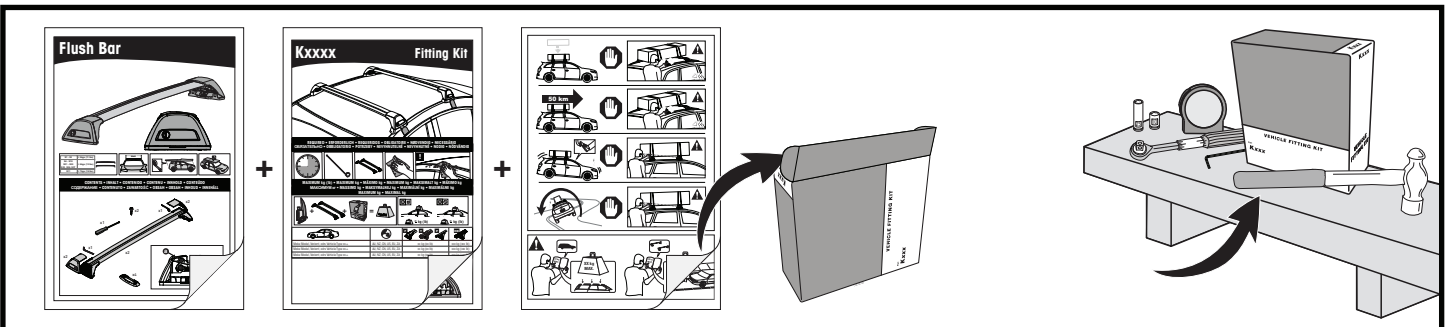
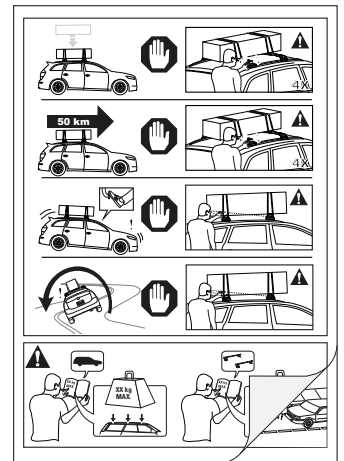

Yakima Australia Pty Ltd
17 Hinkler Court, Brendale
QLD 4500, Australia
1800 143 548
www.prorack.com.au
www.whispbar.com.au
www.yakima.com.au

Yakima Products, Inc.
4101 Kruse Way
Lake Oswego, OR. 97035 USA
888 925 4621
www.yakima.com

WORKS WITH:

